

**Neu/New
Experimental**

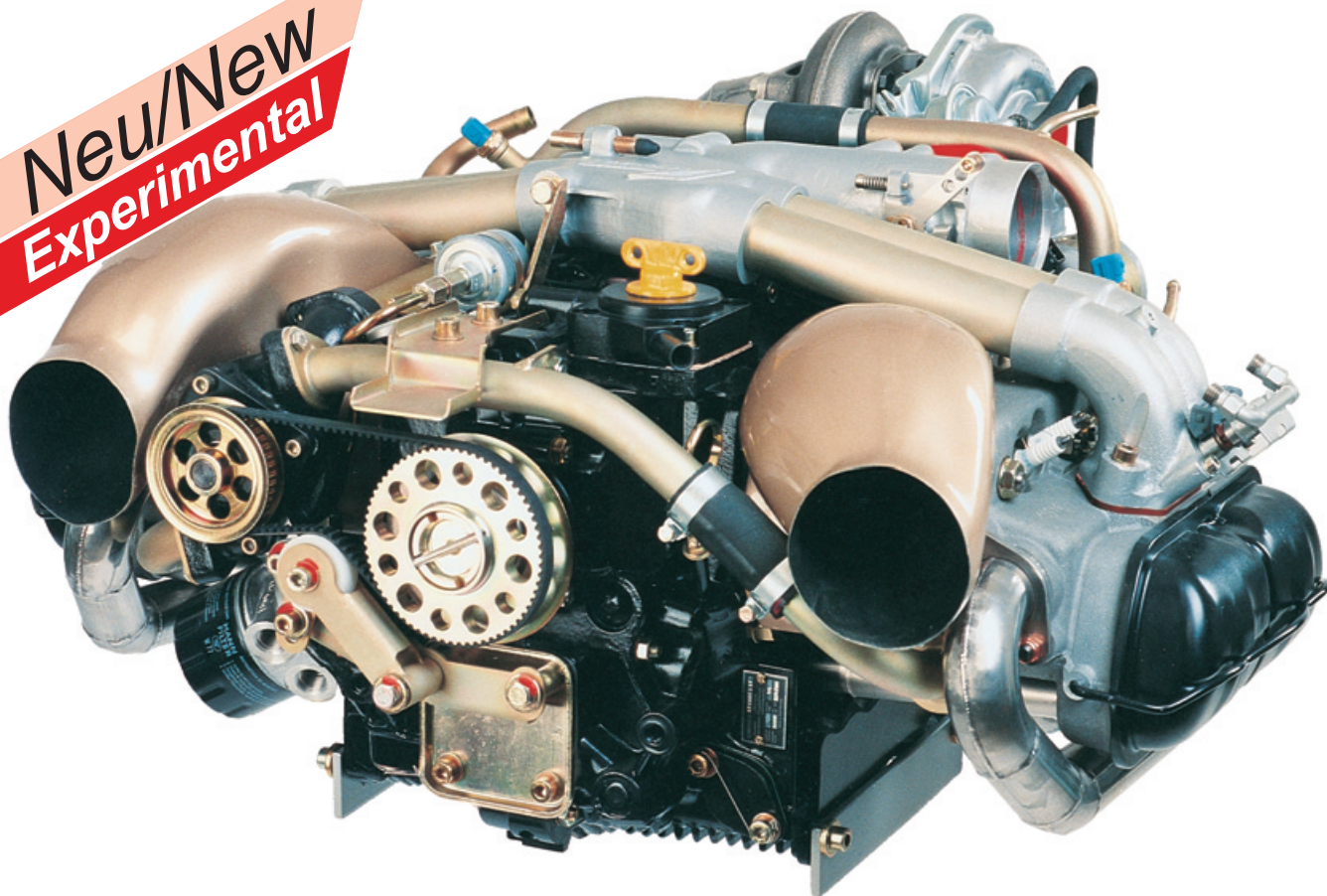

LIMBACH **L 2400 DT.X** - turbocharged

Four cylinder, horizontally opposed engine, with liquid cooled cylinderheads, electronic fuel injection and dual (DT only) ignition system, automatic altitude compensation, wet sump pressure lubrication

Maximum Power*	118 kW / 160 HP at 3000 rpm	Oil temperature	max. 120 °C; min. 50 °C
Bore	97 mm / 3.82 inch	Oil capacity	3.5 ltrs
Stroke	82 mm / 3.23 inch	Coolant temperature	max. 110 °C
Displacement	2424 cm ³ / 147.91 cub. in.	Coolant capacity	approx. 3 ltrs
Compression ratio	8 : 1	Tachometer drive	electric signal
Ignition	Electronic engine management	Propeller drive	direct, anti-clockwise
Spark plugs	NGK DCPR 7 E	Propeller hub	for variable pitch propeller
Electrode spacing	0.7 mm	Dry weight	86 kg, plus accessories
Firing Order	1 - 3 - 2 - 4	Fuel consumption*	255 g/kWh at WOT
Firing point	variable, memory mapped		240 g/kWh at part throttle
Injectors	4 x Weber	Certificate	not certified
Fuel min. octane	98 RON (Unleaded) / AVGAS 100 LL		
Air cleaner	LIMBACH		
Fuel pump	2 x electric 2.5 bar		
Starter with solenoid	12 V - 1.0 kW		
Generator	14 V - 33/55 A		
Oil pressure	max. 7 bar; min. 1 bar at 2500 rpm		

Data may change without prior notice. *Power and fuel consumption data is preliminary!

**Limbach Flugmotoren
GmbH & Co.KG**

**Kotthausener Straße 5
D-53639 Königswinter-Sassenberg
Tel. ++49-2244/9201-0
Fax ++49-2244/9201-30
E-Mail: sales@limflug.de
www.limflug.de**

**Anwendung und Vertriebspartner:
KORFF + Co. KG.
63188 Dietzenbach
Dieselstraße 5
Tel. 06074-40 06-0
Fax 06074-40 06 30**



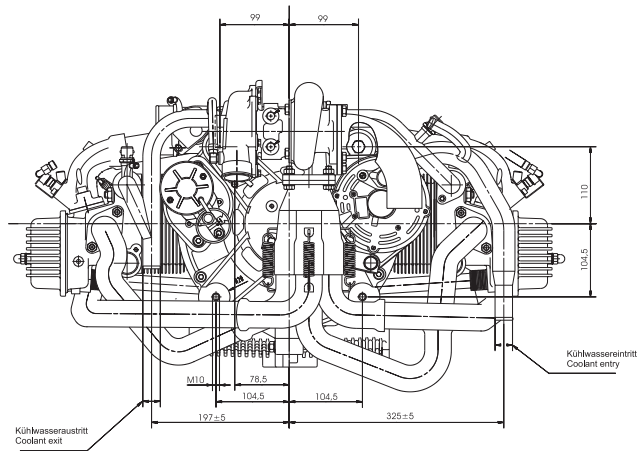
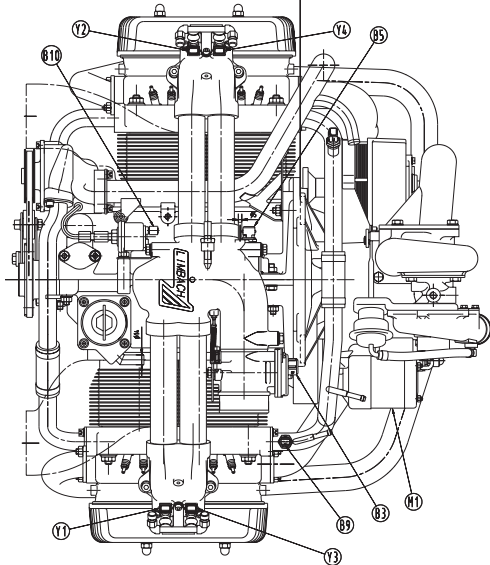
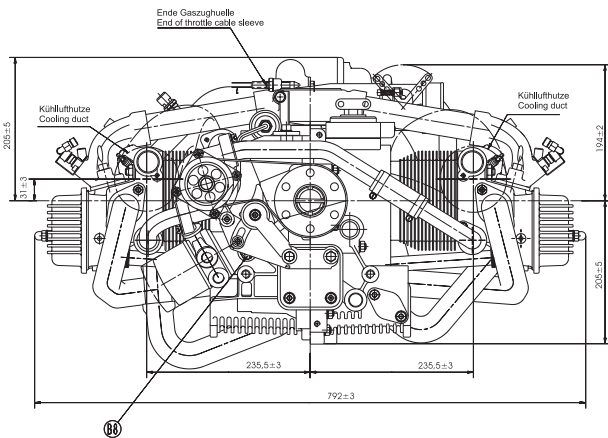
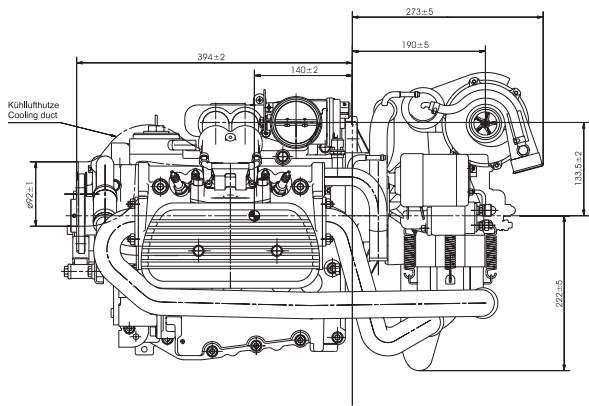

Limbach Flugmotoren
GmbH & Co.KG

Kotthausener Straße 5
D-53639 Königswinter-Sassenberg
Tel. ++49-2244/9201-0
Fax ++49-2244/9201-30
E-Mail: sales@limflug.de
www.limflug.de

Anwendung und Vertriebspartner:
KORFF + Co.KG.
63188 Dietzenbach
Dieselstraße 5
Tel. 060 74-40 06-0
Fax 060 74-40 06 30

