

## LIMBACH **L 2400 DF/EF** - liquid cooled

**Four cylinder, horizontally opposed engine, with liquid cooled cylinderheads, electronic fuel injection and dual (DF only) ignition system, automatic altitude compensation, wet sump pressure lubrication**

Maximum Power	74 kW (100 HP)/3000 rpm	Oil temperature	max. 120 °C; min. 50 °C
Bore	97 mm/3.82 inch	Oil capacity	3.5 ltrs
Stroke	82 mm/3.23 inch	Coolant temperature	max. 110 °C
Displacement	2424 cm <sup>3</sup> /147.91 cub. in.	Coolant capacity	approx. 3 ltrs
Compression ratio	9.5 : 1	Tachometer drive	Electric signal
Ignition	Electronic engine management	Propeller drive	direct anti-clockwise
Spark plugs	NGK DCPR 7 E	Propeller hub	for variable pitch propeller
Electrode spacing	0.7 mm	Dry weight approx.	76 kg, plus accessories
Firing Order	1 - 3 - 2 - 4	Fuel consumption	265 g/kWh at WOT
Firing point	variable, memory mapped		245 g/kWh at part throttle
Injectors	4 x MARELLI	LBA Type Certificate	EASA.E.084 (CS 22-H)
Fuel min. octane	98 RON (Unleaded)/AVGAS 100 LL		
Air cleaner	LIMBACH		
Fuel pump	2 x electric 2.5 bar		
Starter with solenoid	12 V - 1.0 kW		
Generator	14 V - 55 A		
Oil pressure	max. 7 bar; min. 1 bar at 2500 rpm		

**Limbach Flugmotoren GmbH & Co. KG** **Kotthausener Straße 5**  
**D-53639 Königswinter-Sassenberg**  
**Tel. ++49-2244/9201-0**  
**Fax ++49-2244/9201-30**  
**E-Mail: sales@limflug.de**  
**www.limflug.de**

**Side**

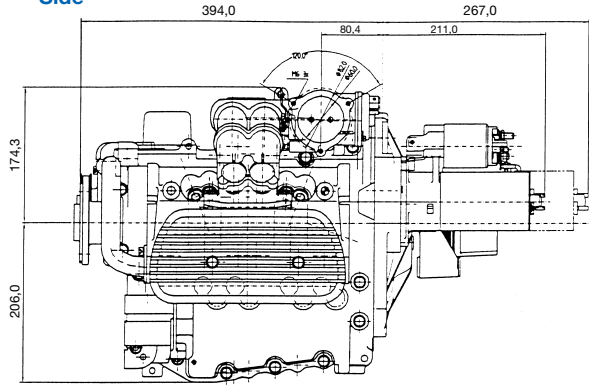

**Front**

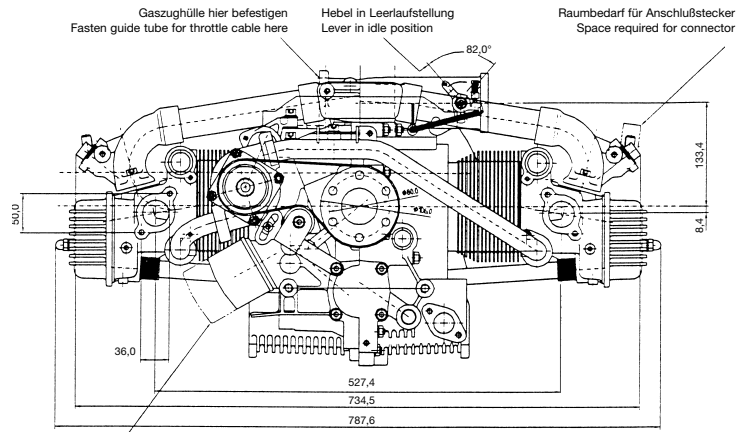

Gaszughülle hier befestigen  
Fasten guide tube for throttle cable here

Hebel in Leerlaufstellung  
Lever in idle position

Raumbedarf für Anschlußstecker  
Space required for connector

Position des Ölfilters bei optionalem Ölkühleradapter  
Position of oil filter with optional oil cooler adapter

**Top**

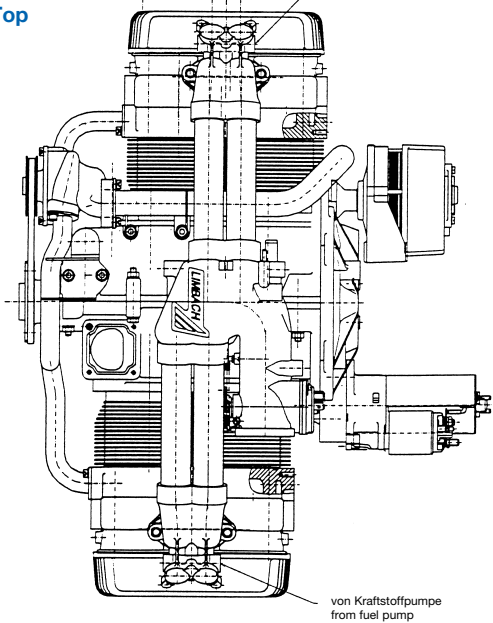

Kraftstoffrücklauf zum Druckregler  
Fuelreturn to pressure regulator

von Kraftstoffpumpe  
from fuel pump

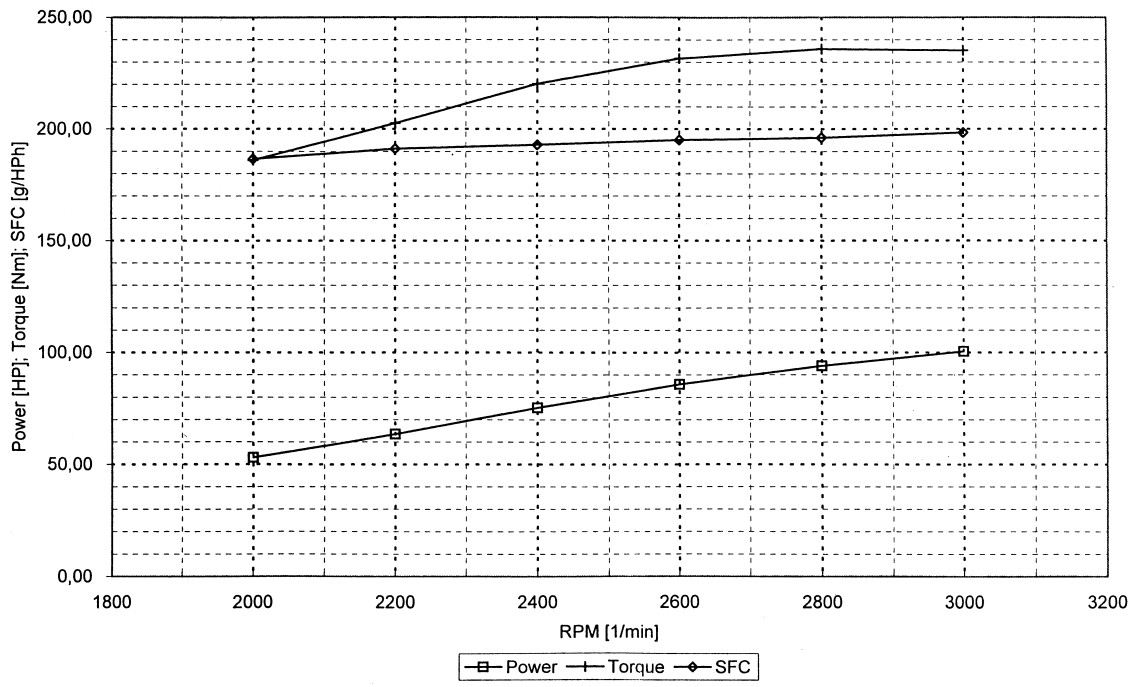

**Limbach Flugmotoren GmbH & Co.KG**  
 Kotthausener Straße 5  
 D-53639 Königswinter-Sassenberg  
 Tel. ++49-2244/9201-0  
 Fax ++49-2244/9201-30  
 E-Mail: sales@limflug.de  
 www.limflug.de